



# ELECTRIC ALLROUNDERS

The benchmark for high-end  
part production

**ARBURG**

# PROFIT- ORIENTED

Typically electric:  
easy implementation of  
demanding tasks.

We set standards! This also applies to our electric ALLROUNDERS. So what does this mean for you? It means, for example, that our drives are designed according to the highest functional and quality criteria - "Made by ARBURG - Made in Germany". Regardless of whether you work with our entry-level GOLDEN ELECTRIC model, our EDRIIVE or our high-precision ALLDRIVE, whether you are at home in the medical-technology, packaging or automotive industry: you produce complex molded parts easily and highly efficiently.

**WIR SIND DA.**

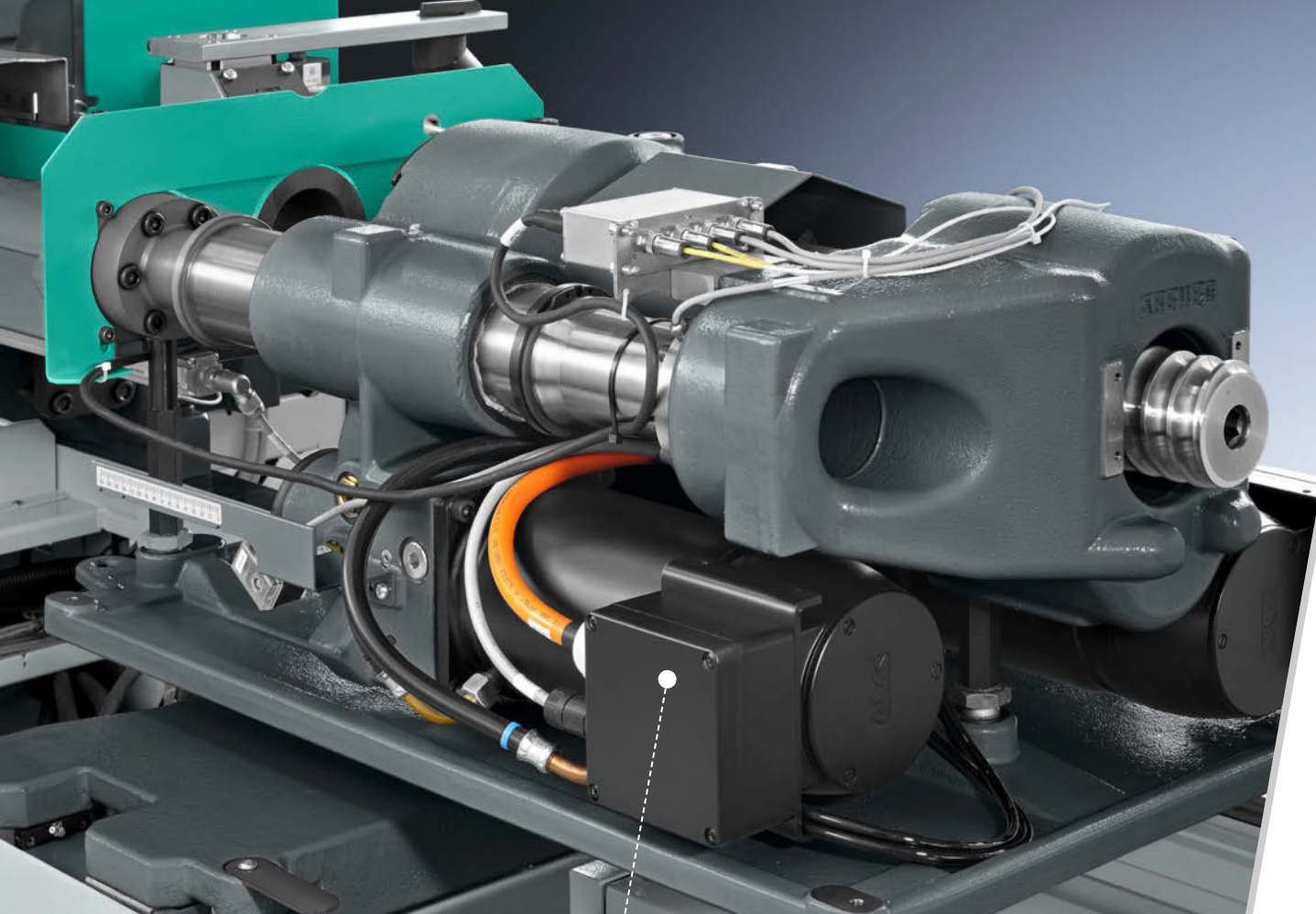

Servo-electric drives operate with great efficiency.

## AT A GLANCE

// Performance-oriented and cost-efficient: With a perfect spectrum of available machine-sizes, our electric machines are suitable for all of your applications. The GOLDEN ELECTRIC is our standardized entry-level model at an unbeatable price. In the case of higher requirements in terms of equipment, our EDRIVE offers additional features. And the more demanding your production tasks become, the more interesting our ALLDRIVE will become for you. Choose your ALLROUNDER from one of the most comprehensive ranges in the industry. \\\

### Modern machine technology for greater allround efficiency

- Short dry cycle times as well as simultaneous machine movements
- Reproducible mold filling
- Extremely low energy requirement
- Low cooling requirement and noise level

## Speed

Injection, dosing and opening and closing of the mold are servo-electrically driven as standard on GOLDEN ELECTRIC, EDRIVE and ALLDRIVE machines and are therefore completely independent. Fast acceleration and speeds, as well as simultaneous movements enable high-speed cycles.

## Energy efficiency

The toggle-type clamping unit, the high efficiency of the servo-electric drives, as well as the recovery of braking energy to the network form the basis for high energy efficiency. The energy requirement is reduced by up to 50 percent.

## Precision

play-free, direct-acting spindle drives provide for mechanically rigid drive axes and dynamic movements. The excellent positioning accuracy of servo-electric drives permits maximum reproducibility and part quality.

## Value

The high degree of reliability of the machines and subsequent minimal variability in the process is achieved through many technical details. This includes, for example, the closed cooling circuit of motors and converters for fast cycles and long holding pressure phases.

## Emission minimization

The liquid-cooled drives operate quietly without air turbulence and reduce emissions into the environment. Closed drives and spindle systems prevent exposure to dust caused by abrasion. Perfect conditions for use in pure production environments.

Uncompromising high-end technology: servo motors are generally liquid-cooled.

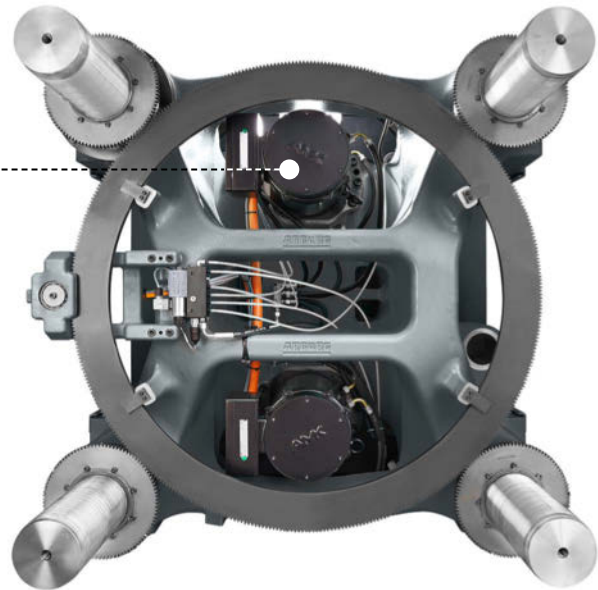

**GOLDEN  
ELECTRIC**

**EDRIVE**

Distance between tie bars: **14.57 - 22.54 inch**

Clamping forces: **65 - 220 tons**

Injection units: **3.7 - 15.3 oz**

**ALLDRIVE**

Distance between tie bars: **10.63 - 44.09 inch**

Clamping forces: **39 - 730 tons**

Injection units: **0.1 - 45.4 oz**

"Made by ARBURG -  
Made in Germany": We consistently  
implement this quality standard.

**ARBURG**  
ALLROUNDER 570 E  
GOLDEN  
ELECTRIC

**GOLDEN  
ELECTRIC**

## LEADING TECHNOLOGY – UNBEATABLE PRICE

// What does the future of injection molding technology look like? One very marked trend is the growing proportion of electric machines in injection molding companies worldwide. With our GOLDEN ELECTRIC series, we are following this trend and have been guided by your requirements in its development. For this purpose, we apply our "golden" recipe for success: the use of proven, uncompromising high-end technology at an unbeatable price. Ideal for producing your quality parts even more profitably! //



Highly compatible: the control system, tie-bar spacings and cylinder modules are the same across all machines series.



Typically "Golden": high-end standards such as play-free spindle gear units.

# EDRIVE AND ALLDRIVE: MORE EQUIPMENT – MORE FLEXIBILITY

// If you want to use modern electric injection molding machines, you will find that we have one of the most comprehensive offerings in the sector. Perhaps you need more flexibility in terms of equipment in addition to our standard entry-level GOLDEN ELECTRIC model? The EDRIVE offers you additional features. You want to handle demanding production tasks efficiently? The high-precision ALLDRIVE can be individually adapted using a variety of performance variants. The choice is yours: just as your application requires. //

## Performance variants

**L1:** The basis for all electric ALLROUNDERS. Designed for technical parts and particularly energy-saving operation.

- Performance specification similar to standard hydraulic machines
- Serial movements by secondary axes (ejector, nozzle movement and core pull) via servo hydraulics
- Regulated mold locking in two stages possible (not for GOLDEN ELECTRIC)

**L2:** An alternative for the ALLDRIVE with high-speed applications and complex processes.

- Shorter dry cycle times and higher injection speeds
- Controlled mold locking in several stages possible
- Dosage across cycles possible

**L3:** An alternative for the ALLDRIVE for thin-walled applications and the highest demands on machine performance.

- All adaptations of performance variant L2
- Even greater injection speeds
- Dosage across cycles

## 100,000,000 CYCLES



This record number for an ALLDRIVE shows just how reliably the electric machines operate





# DRIVE TECHNOLOGY: ENERGY-EFFICIENT

// The high-end drive technology makes our electric ALLROUNDERS extremely economical in every production application. Despite their high dynamics, these machines operate extremely energy efficiently. The basis for this are the servo-electric drives for all important movements, which are available in several performance variants. When it comes to the secondary axes for the ejector, nozzle movement and core pull, you can choose between hydraulic and electric alternatives. This enables you to precisely coordinate machine and application with individual customization. //

Play-free precision: ball screw drives are used on the EDRIIVE and GOLDEN ELECTRIC.

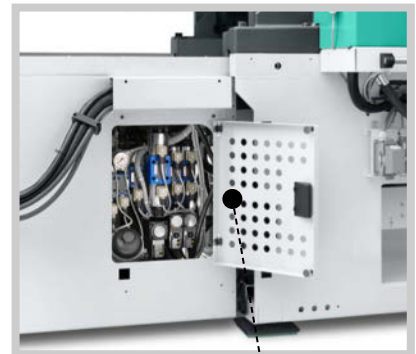
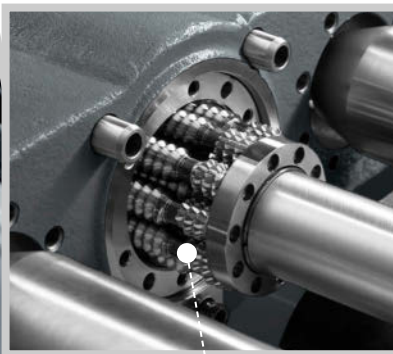
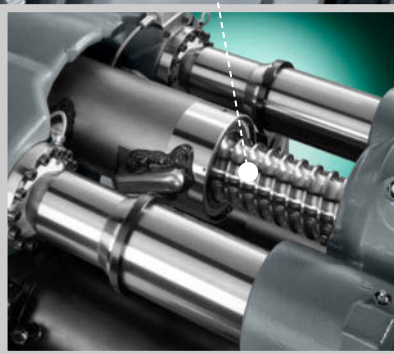

Extremely robust and precise: the highly-stable planetary roller screw drives of the ALLDRIVE series.

Efficient: integrated hydraulics are ideal for high ejector and nozzle contact forces.

## Servo-electric drives

Injection, dosing and mold opening and closing are servo-electrically driven – energy-saving, high-precision and frequently simultaneous movements included. The technical high-end solutions of this area:

- play-free power transmission via direct spindle gear units
- Liquid-cooled servo motors ensure smooth running, temperature stability and operational safety without air turbulence
- Closed cooling circuit for the motors and converters
- Recovery of braking energy

## Integrated hydraulics

The secondary axes are hydraulically driven, while the ejectors and core pulls are also available in servo-electric versions. The servo hydraulics ensure energy-efficient serial sequences. For simultaneous sequences and particularly complex molds, a small hydraulic accumulator system is available as an alternative. You want to use molds with hydraulic functions? No problem with our electric ALLROUNDER!

## High availability

Our robust drive systems are the basis for long, stable, and fault-free running times. The automatic central oil lubrication system and the grease lubrication points that converge at a central point outside the paneling minimize the maintenance effort for the toggle-type clamping units. Because lubrication can take place during operation without interrupting production, availability is increased. Lubrication intervals are thereby calculated individually, depending on the forces, speeds, strokes, and times that have been set. This type of predictive maintenance saves operating time and minimizes costs. All this means greater cost-effectiveness in day-to-day operation.

Compared to the hydraulic standard up to

**50 %**  
**ENERGY SAVING**



Maintenance-friendly: automatic central oil lubrication of the clamping unit.



Easy access: cross-series ejector quick-connect coupling simplifies set-up.

Generous installation space and opening stroke: also suitable for large molds.

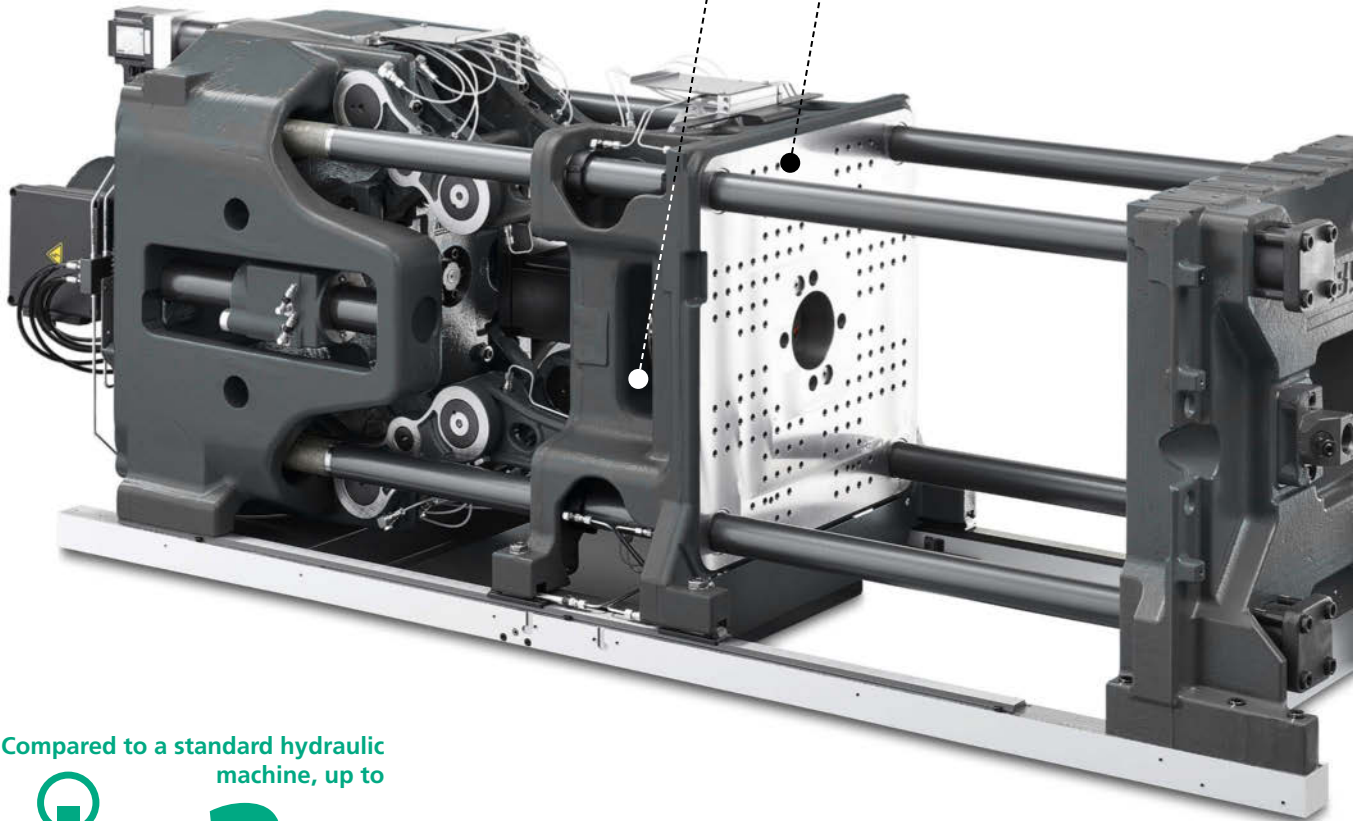

Compared to a standard hydraulic machine, up to



**2 s**  
SHORTER  
DRY CYCLE TIME

## CLAMPING UNITS: FAST

// High-precision and cost-efficient: our electric toggle-type clamping units. Save money daily with energy-efficient running characteristics! The kinematics of the double five-point toggle are optimally adapted to the servo-electric drive. The application-oriented design of the drive technology on the GOLDEN ELECTRIC, EDRIIVE and ALLDRIVE machines ensures short dry cycle times. In addition, the simultaneous movements of the clamping unit and ejector considerably reduce cycle times in your production facility. //

## Five-point toggle system

The double five-point toggle features a stable construction with multiple guidance points. This provides for absolutely symmetrical force application during movements and mold locking – even with heavy molds. Despite the compact design, large opening strokes are possible.

## Protective mold use

The box-type construction of the movable platen is longitudinally guided and supported. Together with four tie-bar guidance, this results in high-level parallelism and precision for extended mold service life. Highly sensitive tie bar strain measurement ensures active mold protection.

## Precise positioning

The heart of our mechanically-rigid clamping system: the play-free spindle gear unit. This enables us to assume all positions with a high degree of precision. This simplifies the transfer of parts to robotic systems.

## Clamping force control

The toggle can conveniently be adapted to different mold installation heights by means of an electrical adjustment. The clamping force control (depending on the series and performance variant) generates a consistent locking force and thus automatically compensates for the thermal expansion of the mold.

Media connections close to the mold (optional): the increased protection towards the back of the machine provides for much free space.

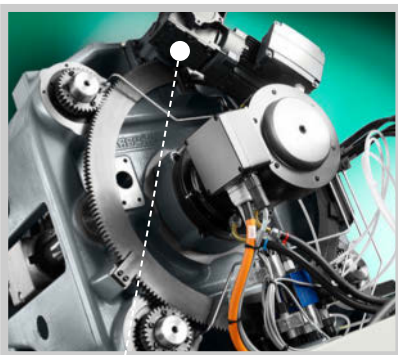

Electric mold height adjustment: effective help for short set-up times.

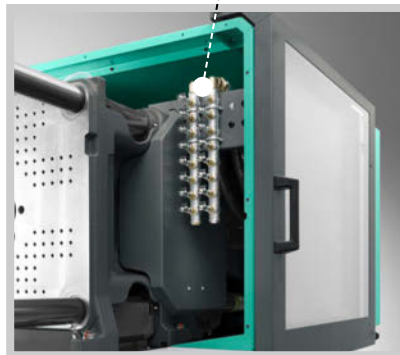

Servo-electric ejectors (optional): particularly precise dropping of molded parts for even shorter cycle times.





Swiveling injection unit: the screw can be removed without dismantling the cylinder module.



Simple changeover: Central connection of all cylinder module supply units and screw quick-connect coupling.



## INJECTION UNITS: PRECISE

// Homogeneous material preparation and precise injection form the basis for high-quality part production. This is ensured, for example, by the mechanically rigid drive axes, which ensure excellent process control. Another benefit is found in potential energy savings. With the ALLDRIVE, you maintain full control of your cycle times thanks to simultaneous nozzle movement and dosage across cycles. Another definite advantage for you: our injection units can be converted and cleaned quickly. //



**SMALL  
SHOT WEIGHTS**

can be reproduced in the  
micro injection unit



### **Wide variety of combinations**

The cylinder modules are compatible with all series and are finely graded. Various versions ensure optimum protection against wear. In addition, screws in special geometries allow you to process all common plastics.

### **Servo-electric injection**

Reproducible mold filling is achieved by force- and position-regulated injection, dynamic acceleration and precise pressure detection via sensors close to the axis. Liquid-cooled motors enable fast cycles and long holding pressure phases.

### **Torque-free nozzle contact**

Our two-tie-bar guide facilitates absolutely leak-tight nozzle contact – also ideal for both flat and extended nozzles. The build-up of the nozzle contact forces is programmable and regulated, which reduces wear on the nozzle and mold.

### **Direct dosing drive**

The independent servo-electric injection and dosing drives allow for regulated dynamic pressure and lead to higher energy efficiency and precision. Since the melt can be dosed simultaneously and cyclically on the ALLDRIVE, it can also be processed faster and more gently.



## CONTROL SYSTEM: SMART

// Maintaining control over machine, mold, robotic and peripheral technology requires a suitably powerful central control system. “Smart technology” is called for, which can be easily integrated, supports you actively in all operating situations as well as monitors and adaptively controls your process. All the features of our SELOGICA control system are designed for a fast, reliable and comfortable set-up and operating process. This allows you to get the best out of all your applications. //

### Highlights

- Graphic sequence programming
- Direct plausibility checks
- Assistance packages and connectivity modules  
“Ready for Digitalization”
- Central control system for complete production cells

## Central management

Thanks to its unsurpassed standard operating system, the SELOGICA saves time and costs. The simple integration of different peripheral equipment enables sequence management even for complete production cells, with only one data set. Short cycle times? Can be programmed!

## Intuitive operation

The graphics-based operational philosophy can be comprehended intuitively and is always geared towards optimization of the processes. Our unique graphical sequence programming with direct plausibility check always clearly indicates the logical position of the current programming step. Operating errors? Out of the question!

## Efficient operation

This calls for a "smart machine" that offers extensive data integration options, monitors and adaptively controls your processes, and supports you in every operating situation: from set-up and start-up, through optimization and production, to monitoring and service. This is where our connectivity modules and assistance packages come into play. "Ready for Digitalization"? Of course!



Nothing is impossible! Multiple functions for specialized technology, with which even special procedures become standard for you.

One for all: consistent use of the same operating philosophy means less training and set-up effort.



# APPLICATIONS: IN PRACTICE

// Medical technology parts in the clean room, packaging in large unit volumes, safety-related products in the automotive industry or even reproducible production of precision small parts at a constant quality level: these are the requirements that are covered perfectly by our electric ALLROUNDER machines. With our attractive entry-level GOLDEN ELECTRIC model, the EDRIVE or the highly precise, individually adjustable ALLDRIVE; our high-end technology proves its worth day after day, directly in your production operations. //

Complex technical parts:  
complete turnkey systems  
from a single source.

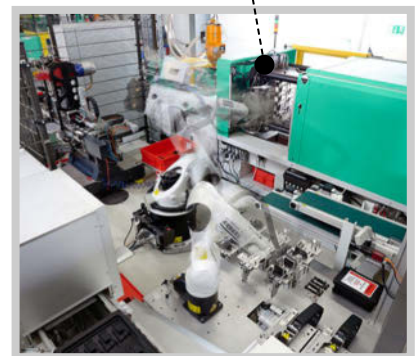

High-volume medical technology  
items: profit-oriented unit costs  
thanks to short cycle times.



Rain/light sensor (automotive)



High-output production:  
synchronous ejection enables  
even faster cycles.



Micro-injection molding:  
extremely small shot weights thanks  
to the 0.1 oz micro-injection unit.

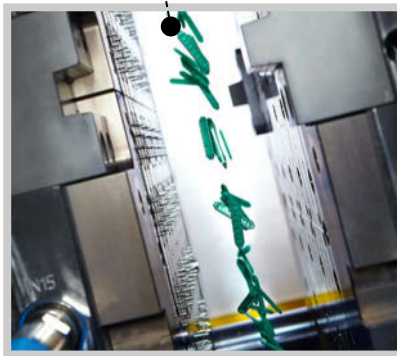

Optical parts: excellent  
reproducibility with  
servo-electric drives.



Further information:  
application expertise brochure



Scan this code to visit our  
Media Center: in-depth,  
captivating, entertaining.

**ARBURG GmbH + Co KG**  
Arthur-Hehl-Strasse  
72290 Lossburg  
Tel.: +49 7446 33-0  
[www.arburg.com](http://www.arburg.com)  
[contact@arburg.com](mailto:contact@arburg.com)

**WIR SIND DA.**