

RAPID PRO-SENSE 6

High-performance metal separator for resin and compound manufacturers

- Metal contaminations in plastic material are one of the most frequent reasons for machine downtimes and quality defects in the plastics industry.
- It is therefore important for resin and compound manufacturers to carry out quality control concerning metal contaminations.
- This ensures consistent product quality, protects against complaints and avoids high costs for returns.

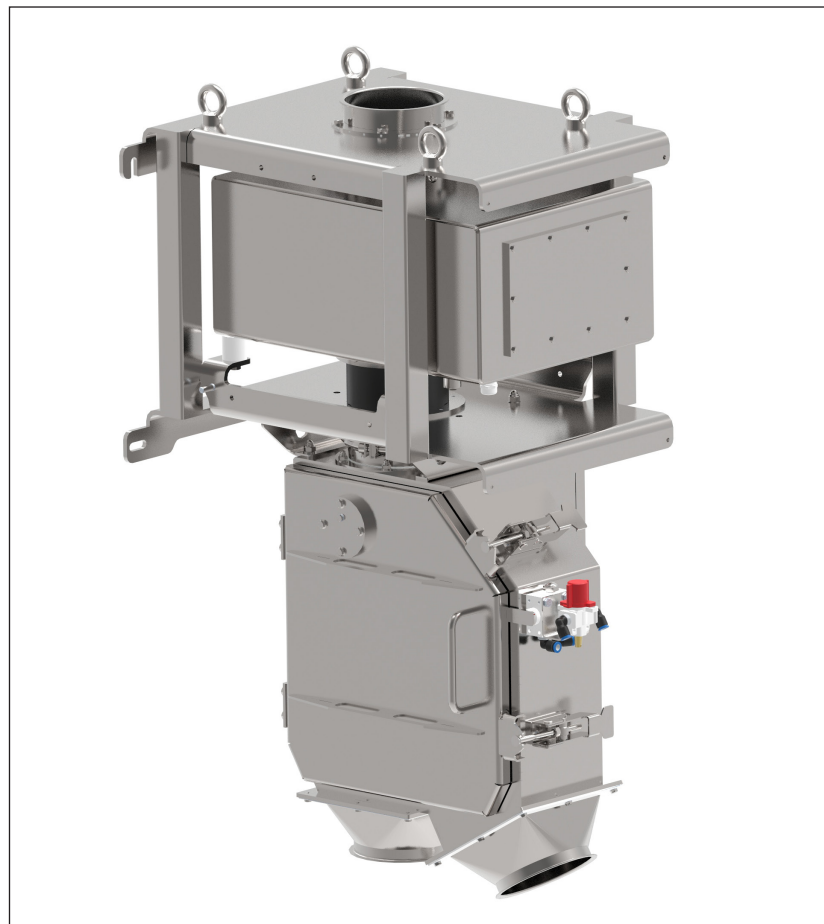

Metal separators for use in resin and compound production must meet specific requirements:

- Detection of smallest metal contaminations, even in large pipe diameters
- Frequent colour and material changes
- Easy and quick cleaning
- Application with abrasive materials

Benefits:

The RAPID PRO-SENSE 6 metal separator supports compounders to provide quality control, process reliability and economic efficiency.

Quality control

- Consistent product quality
- Prevention of complaints caused by metal inclusions
- Traceability through logbook function

Process reliability

- Reliable and fast cleaning even in complex installation situations
- Reproducible cleaning process

Economic efficiency

- More uptime through short cleaning times
- Reduced manual effort

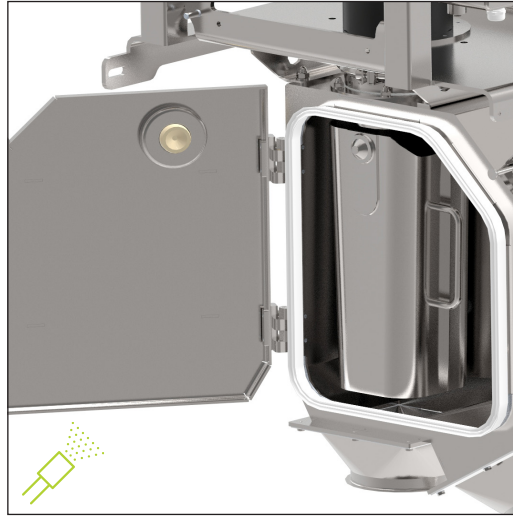

*Tool-free cleaning and easy maintenance of the reject unit
 Option: Automatic cleaning with washing nozzles*

Application:

- Inspection of bulk materials in free-fall conveying lines
- Incoming goods inspection of plastic resin and flakes
- Outgoing quality control (e.g. filling station)

Features:

- Highest detection accuracy
- Nominal diameter 50 mm – 250 mm
- Toolless opening and cleaning of reject unit (patent pending)
- Option: automatic cleaning function with washing nozzles (patent pending)
- No sealing gaskets in contact with product (silicone-free)
- Ease-of-use: GENIUS ONE control unit with logbook function
- Wear-resistant design optionally available
- Ethernet interface (IOT-ready) included as standard

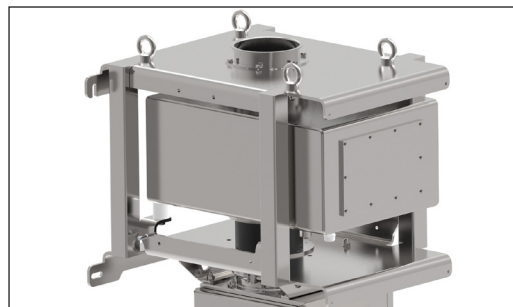

*Highest detection accuracy with HRF technology
 (High Resolution Frequency)*

Sesotec Service:

Contact us for available maintenance packages and service offers.



Safety



Economic efficiency



Performance



Satisfaction



*Electronic Control Unit GENIUS ONE with 5" colour
 touchscreen (Industry 4.0-ready / IOT-ready)*

